



GREEN CLIMBER

LV 800 PRO



***A STURDY MACHINE FOR
THE TOUGHEST TASKS***

*DESIGNED FOR FOREST MAINTENANCE WORK; A WIDE RANGE
OF ATTACHMENTS SUITABLE FOR HEAVY FORESTRY TASKS
LIKE FELLING TREES, STUMP GRINDING AND WOOD CHIPPING.*



LOWER FUEL CONSUMPTION, BETTER MANOEUVRABILITY AND EASIER TRANSPORT

Compact dimensions and low weight allow Green Climbers to have the best power-to-weight ratio.



GREATER STABILITY

The variable width undercarriage achieves an unrivalled stability on uneven and steep terrain and can be adjusted directly from the remote control.



GREATER FLEXIBILITY

The tool's lateral movement enables work beyond the machine's footprint of up to 1000 mm.



GREATER STABILITY AND TRACKS ALWAYS IN PLACE

Our undercarriage with its patented track guard system dramatically increases stability and reliability.



WORK IN ANY DIRECTION ON SLOPES OF UP TO 60°

Lowest centre of gravity in its category. This means that Green Climbers can work even in extreme conditions.



MAXIMUM STRENGTH

The high-strength steel frame makes our Green Climbers the lightest in its class. A winch mounted on the rear bar is part of the standard configuration of the LV 800 PRO.



INCREASED FOOTPRINT

The LV 800 PRO has the ability to work even on muddy or loose soil.



TIME SAVINGS

The rapid connect/disconnect system allows for time savings for changing the attachments. A tool-less method to change attachments for the necessary job.



Green Climber – LV 800 PRO

TECHNICAL SPECIFICATIONS

Dry Weight	1910 kg
Work Gradient	60°
Extendable Undercarriage	1510 mm / 1910 mm
Attachment Sideshifting	500 mm + 500 mm
Engine	KOHLER KDI2504TCR/26°
N. of Cylinders	4
Engine Power	74.3 hp / 55.4 kw
Engine Torque	315 Nm @ 1500 rpm
Emissions	Stage V – EPA Tier 4 Final
Fuel Tank Capacity	52 L Diesel
Cooling System	Liquid
Main Attachment Pump	106 L/m @ 350 bar
Service Pump	35 L/m @ 180 bar
Hydraulic Oil Tank Capacity	32 L
Hydraulic Auxiliary Lines	3 Proportional
Transmission	Hydraulic Proportional
Speed	9 km/h
Reversible Fan	Yes

© MDB Srl 2024 - Image, technical and construction specifications subject to change with no obligation of prior notification. All rights reserved.

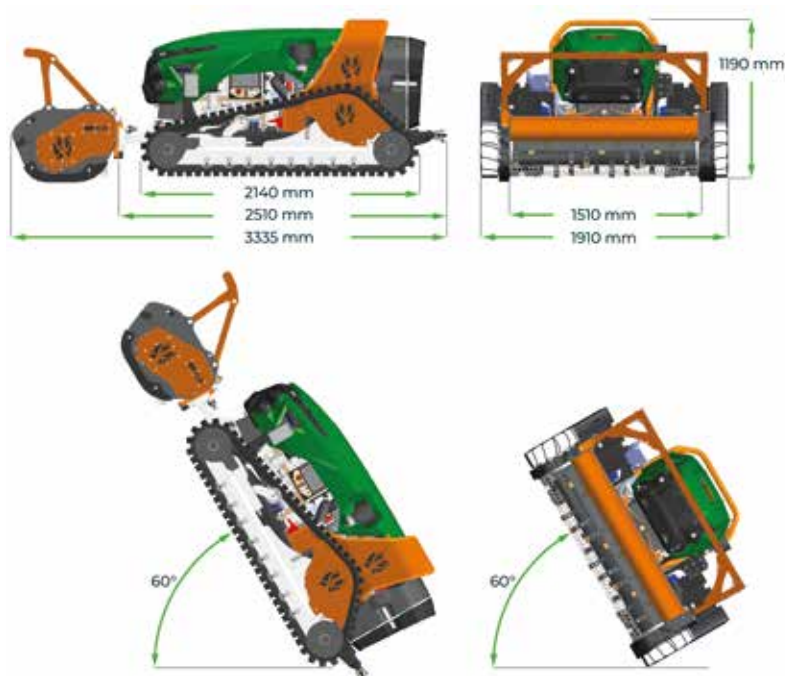

MDB srl
www.mdb srl.com
Via Cupone 13
66022 Fossacesia (CH)
Italia

