



GREEN CLIMBER
LV 600 PRO



**A STURDY MACHINE FOR
THE TOUGHEST OF TASKS**

**VARIOUS ACCESSORIES AVAILABLE FOR LANDSCAPE
MAINTENANCE, CLEARING ROAD BANKS OR FORESTRY TASKS.**



LOWER FUEL CONSUMPTION, BETTER MANOEUVRABILITY AND EASIER TRANSPORT

Compact dimensions and low weight allow Green Climbers to have the best power-to-weight ratio.



GREATER STABILITY

The variable width undercarriage achieves an unrivalled stability on uneven and steep terrain and can be adjusted directly from the remote control.



GREATER FLEXIBILITY

The tool's lateral movement enables work beyond the machine's footprint of up to 1000 mm.



WORK IN ANY DIRECTION ON SLOPES OF UP TO 60°

Lowest centre of gravity in its category. This means that Green Climbers can work even in extreme conditions.



CONTINUOUS OPERATIONS

The reversible fan and oversized radiator allow continuous work in dusty and high temperature environments.



GREATER STABILITY AND TRACKS ALWAYS IN PLACE

Our undercarriage with its patented track guard system dramatically increases stability and reliability.



INCREASED FOOTPRINT

The LV 600 PRO has the ability to work even on muddy or loose soil.

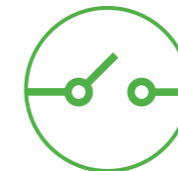

TIME SAVINGS

The rapid connect/disconnect system allows for time savings for changing the attachments. A tool-less method to change attachments for the job at hand.



Green Climber – LV 600 PRO

TECHNICAL SPECIFICATIONS

Dry Weight	1520 kg
Work Gradient	60°
Extendable Undercarriage	1360 mm / 1760 mm
Attachment Sideshifting	500 mm + 500 mm
Engine	KOHLER KDI1903TCR
N. of Cylinders	3
Engine Power	56.3 hp / 42 kw
Engine Torque	225 Nm @ 1500 rpm
Emissions	Stage V - EPA Tier 4 Final
Fuel Tank Capacity	34 L Diesel
Cooling System	Liquid
Main Attachment Pump	83 L/m @ 320 bar
Service Pump	22 L/m @ 180 bar
Hydraulic Oil Tank Capacity	32 L
Hydraulic Auxiliary Lines	3 Proportional
Transmission	Hydraulic Proportional
Speed	9 km/h
Reversible Fan	Yes

© MDB Srl 2024 - Image, technical and construction specifications subject to change with no obligation of prior notification. All rights reserved.

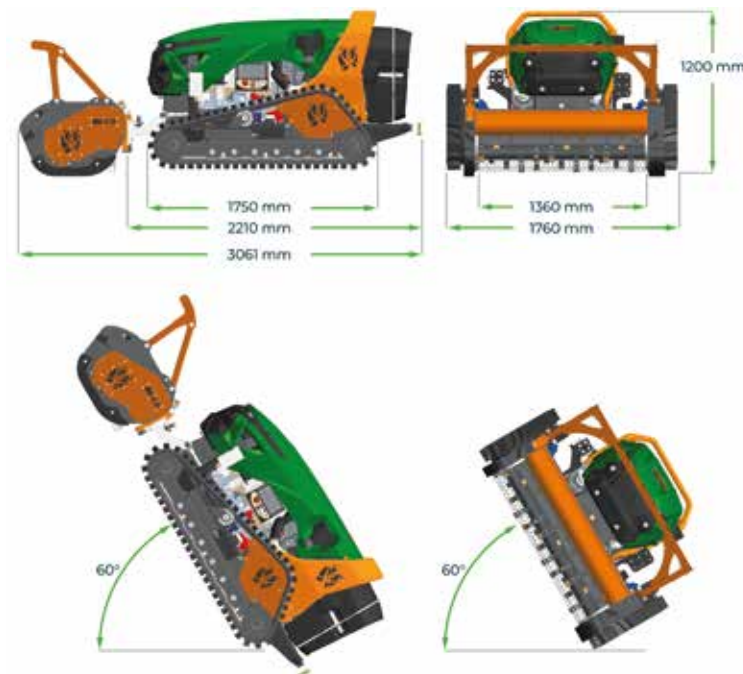

MDB srl

www.mdb srl.com

Via Cupone 13
66022 Fossacesia (CH)
Italia

